



**Lochinvar**<sup>®</sup>  
High Efficiency Water Heaters, Boilers and Pool Heaters

**COMMERCIAL ELECTRIC  
STEAM BOILER  
Submittal Sheet**

**EBS-Sub-02**

**COMMERCIAL ELECTRIC STEAM BOILERS**

**JOB NAME** \_\_\_\_\_

**LOCATION** \_\_\_\_\_

**ARCH./ENGR.** \_\_\_\_\_

**WHOLESALE** \_\_\_\_\_

**MECH. CONTRACTOR** \_\_\_\_\_

**MODEL NO.** \_\_\_\_\_

**GALLON CAPACITY** \_\_\_\_\_

**VOLTAGE PHASE** \_\_\_\_\_

**KW** \_\_\_\_\_

**NOTES**

**Standard Features**

- ASME National Board Registered Pressure Vessel
- Heavy Duty Steel Boiler Vessel Housing
- 3" Fiberglass Insulation
- ASME Pressure Relief Valve
- Pressure Gauge with Gauge Cock
- Feedwater Stop & Check Valves
- Full-Port Bottom Blowdown Valve
- Combination Float-Type Level Control /  
  Low Water Cut-Off with Blowdown Valve
- Water Level Sight Gauge with Blowdown Valve
- Surface Blowoff Provision
- Low Water Cut-Off with Manual Reset & Pilot Light
- Adjustable High Limit with Automatic Reset
- Adjustable High Limit with Manual Reset
- Incoloy-Sheathed Elements
- Internal Branch Circuit Fusing
- Magnetic Contactors
- Main Supply Circuit Lugs
- 120 Volt Fused Control Transformer
- On/Off Switch with Pilot Light
- Preheat Switch with Pilot Light (above 240 kW)
- Key Locked Door
- Electric Control Panel
- Staged On/Off Pressure Switches (1, 2 & 3 Step Models)
- Proportional Solid State Step Control  
  (models with more than 3 Steps)
- Status Pilot Light for each Stage/Step
- Listed by the Underwriters Laboratories
- 3 Year Limited Tank Warranty / 1 Year Parts Warranty  
  (See warranty for details)

**Optional Features**

**Place an X in the box by all options that apply**

- Alarm Bell
- Automatic Breaker
- Automatic Feed Water Solenoid Valve
- Fused Disconnect
- Ground Fault Detector
- Kilowatt/Hour Meter
- Main Power Disconnect
- Manual Limit Toggle Switches (1 per Step)
- Automatic Timed Surface Blowoff System

**OPTIONAL CONTROLS**

***Modulating Step Control (Progressive)***

- 5-Step
- 10-Step
- 15-Step
- 20-Step

# Commercial Electric Steam Boiler Dimensions & Specifications

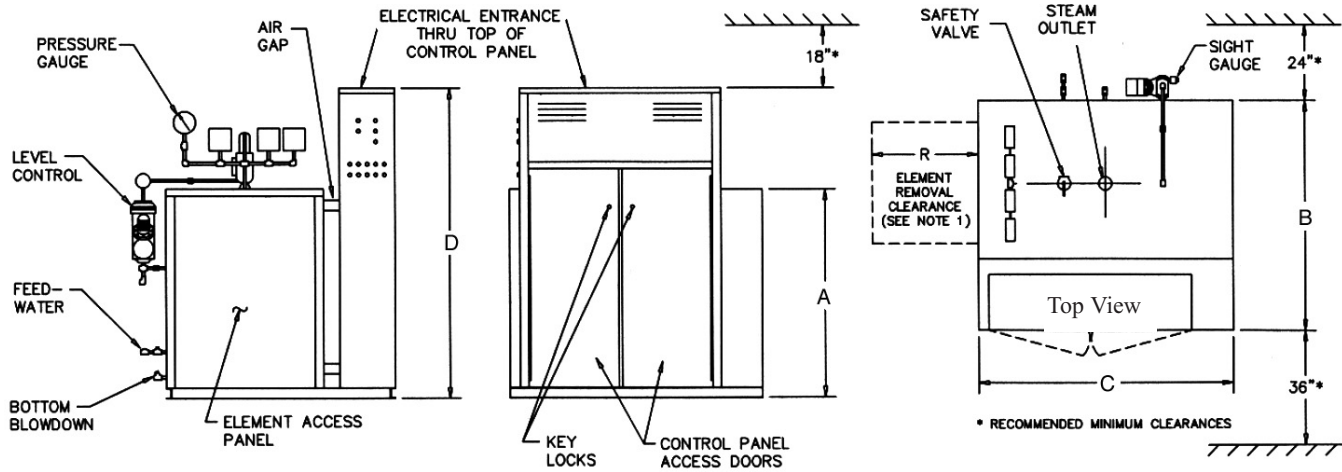

Note 1: Element removal clearance (R) is equal to 2 times the element KW.

Model Number	Max. Steam Input kW	F&A 212°F (PPH)	Max. # of Elements	Connection Sizes (NPT)					Tank Data			Dimensions (Inches)				Weight (lbs)	
				Feed Water	Blowdown 15psi	>15psi	Steam Outlet 15psi	50psi	150psi	Dims (In)	Vol (Gal)	A	B	C	D	Ship	Oper.
BS*12	60	205	3	1/2"	3/4"	3/4"	1-1/4"	1"	3/4"	12x42	20	22"	28"	50"	25"	550	650
BS*16	140	478	7	1/2"	3/4"	3/4"	2"	1"	3/4"	16x42	32	26"	32"	50"	33"	750	910
BS*16	200	682	10	1/2"	3/4"	3/4"	2"	1-1/4"	3/4"	16x42	32	26"	32"	54"	33"	800	960
BS*20	240	819	12	3/4"	1"	1"	2-1/2"	1-1/4"	1"	20x42	41	30"	36"	50"	51"	1000	1200
BS*20	320	1092	18	3/4"	1"	1"	3"	1-1/2"	1"	20x42	41	30"	36"	54"	51"	1050	1250
BS*24	360	1228	18	3/4"	1-1/4"	1"	3"	1-1/2"	1-1/4"	24x44	74	34"	40"	52"	51"	1300	1670
BS*24	600	2047	30	3/4"	1-1/4"	1"	4" FLG	2"	1-1/2"	24x44	74	34"	40"	56"	51"	1400	1770
BS*30	960	3276	48	3/4"	1-1/2"	1"	6" FLG	3" FLG	2"	30x46	124	40"	48"	60"	63"	1700	2340
BS*36	1280	4367	64	1"	1-1/2"	1"	6" FLG	3" FLG	2"	36x46	166	46"	54"	60"	63"	2100	2960
BS*42	1880	6415	94	1"	1-1/2"	1"	8" FLG	4" FLG	3" FLG	42x48	230	52"	62"	64"	81"	2800	4000
BS*48	2400	8325	122	1"	2"	1-1/4"	8" FLG	5" FLG	3" FLG	48x54	345	58"	63"	70"	87"	4600	6300
BS*54	3040	11598	152	1-1/4"	2"	1-1/4"	10" FLG	6" FLG	4" FLG	54x60	500	66"	74"	76"	89"	5600	8100



Lochinvar Corporation • 300 Maddox Simpson Pkwy • Lebanon, TN 37090 • 615-889-8900/Fax: 615-547-1000

www.Lochinvar.com